

**SQLdays**  
konferenz

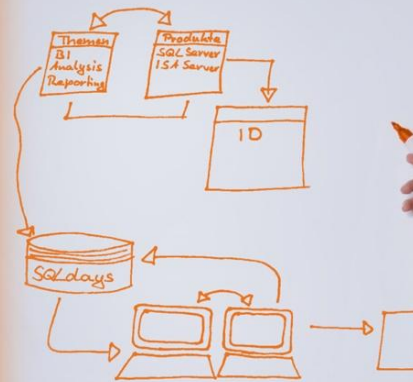

Veranstalter:



# SQL 2008R2: CPU's, Cores und CPU-Gruppen verwalten

=tg= Thomas Grohser  
tg@grohser.com

# select \* from =tg=

@@Version	Remark
SQL 4.21	First SQL Server ever used (1994)
SQL 6.0	First Log Shipping with failover
SQL 6.5	First SQL Server Cluster (NT4.0 + Wolfpack)
SQL 7.0	2+ billion rows / month in a single Table
SQL 2000	938 days with 100% availability
SQL 2000 IA64	First SQL Server on Itanium IA64
SQL 2005 IA64	First OLTP long distance database mirroring
SQL 2008 IA64	First Replication into mirrored databases
SQL 2008R2 IA64	First 256 CPUs & >500.000 STMT/sec
SQL 11 (Denali)	Can't wait to push the limits even further

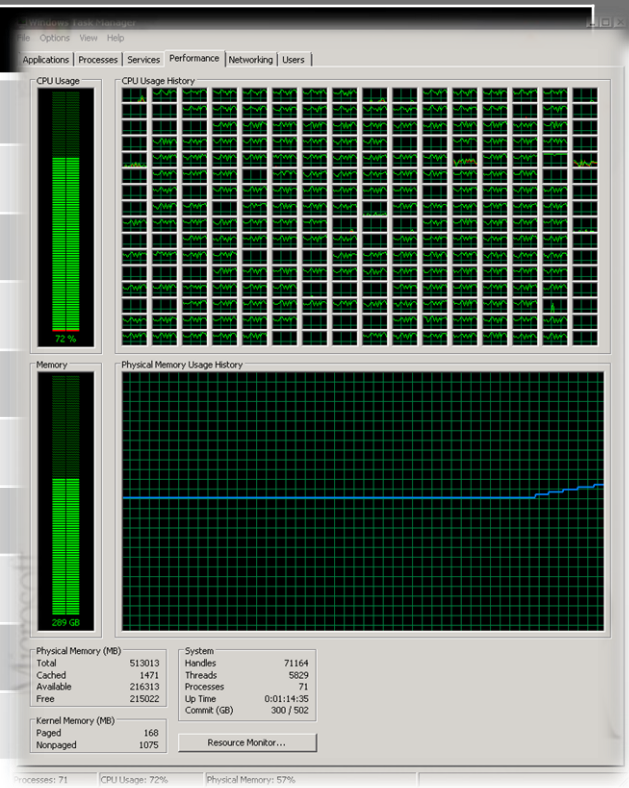

**Thomas Grohser, SQL Server MVP, bwin Interactive Entertainment AG**

Focus on SQL Server Infrastructure Architecture and Implementation

**Close Relationship with Microsoft**

SQLCAT (SQL Server Customer Advisory Team)

SCAN (SQL Server Customer Advisory Network)

TAP (Technology Adoption Program SQL2008R2 and SQL11)

**Active PASS member and PASS Summit Speaker**





World's biggest publicly listed online gaming platform

World's leading provider of online Sports Betting

One of the largest **Poker networks**

Comprehensive range of **Payment Service Providing**

Integrated gaming portal - **22 languages,**  
**25 core markets**

Gross gaming revenues 2008 (GGR):  
**EUR 421 million**

More than **20 million** registered customers

**1,500** employees

bwin builds on the strengths of the web in order  
to **tie up responsibility and gaming**

**15 million** page views and up to **980,000**  
**users a day**



# Agenda

- **Relevant Components of a Server (CPU, RAM, I/O)**
- **IA64, x64, x86 – Overview over the architectures**
- **Which architecture is best for which workload**
- **NUMA – Why it's a good thing and you should become friends**
- **Affinity how to increase performance and save money**
- **Questions and answers**

# My favorite new SQL2008 R2 feature

# CREATE INDEX WITH A SMILE

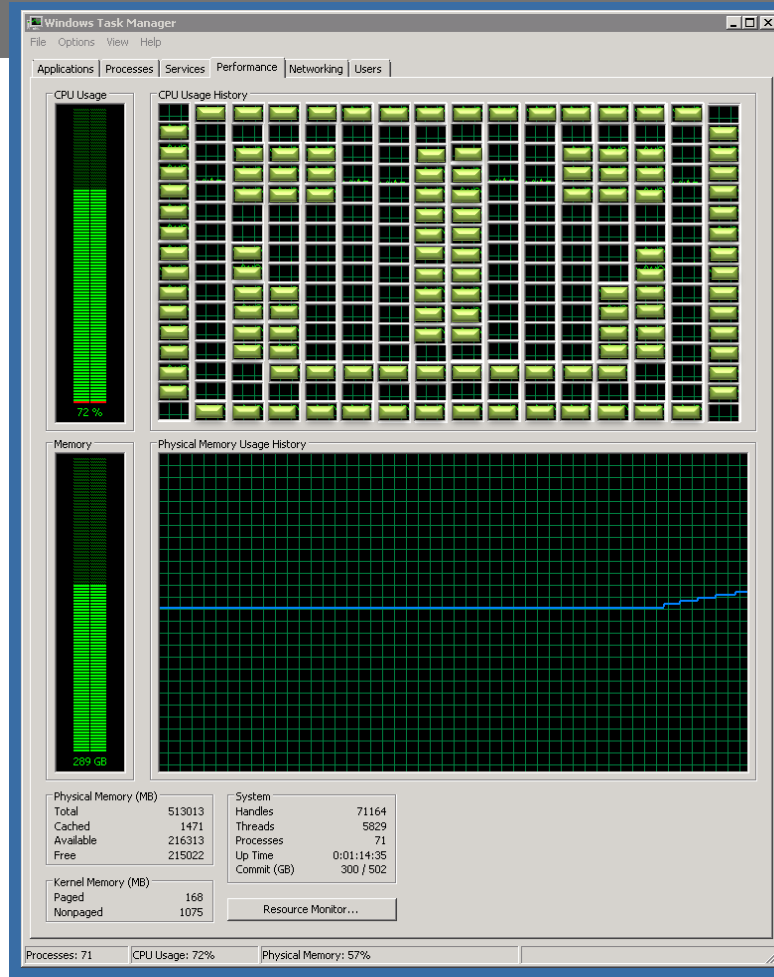

# Relevant Components of a Server

- **CPU's**                      **Central Procession Units**
- **RAM**                        **Random Access Memory**
- **I/O**                         **Input/Output**
- **Storage**
- **SAN, DAS, SSD**  
**(Solid State Devices)**
- **Network**
- **Display**
- **Keyboard**

# IA64, x64, x86

- **x86 or IA32**
- **32 bit Address space**
- **Intel and AMD**
- **x64**
- **AMD and Intel**
- **x86 backward compatible  
(native execution,  
wrapper dll's into the OS)**
- **IA64 – Itanium 2 64 Bit**
- **Intel**
- **x86 and backward compatible  
(emulated execution)**

# History and a glimpse in the future

- **SQL Server**
- **SQL 4.21** x86
- **SQL 6.0/6.5** x86
- **SQL 7.0**  
x86
- **SQL 2000** x86, IA64
- **SQL 2005** x86, x64, IA64
- **SQL 2008** x86, x64, IA64
- **SQL 2008 R2** x86, x64, IA64
- **SQL Denali** x64 only
- **Windows Server**
- **NT 3.x**  
x86
- **NT4.0**  
x86
- **Windows 2000**  
x86, IA64
- **Windows 2003**  
x86, x64, IA64
- **Windows 2003 R2** x86, x64, IA64
- **Windows 2008**  
x86, x64, IA64
- **Windows 2008R2**  
x64, IA64
- **Windows ????**  
x64 only

# Which Architecture for which Workload

- **x64 is the future and best compromise**
- **Special cases**
  - **x86 – Very Small databases that need to be extra fast**
  - **IA64 – Very I/O intense databases**

# What is NUMA?

- **None**
  - **Uniform**
  - **Memory**
  - **Access**
- 
- **OK - but what the heck does that mean?**

# Why is Memory Important?

- **Memory is fast**

- Disk access is measured in ms
- Memory access in ns
  
- If snapping your finger once a second is memory access
- Doing it every 11 days is disk access

# Why is Memory Important?

- **SQL Server is a in memory database**
- **All Query Requests and DML statements and even all DDL statements work only on data in memory**
- **If data required for the operation is not in memory it is loaded from disk into memory first**
- **Data is written back to disk at a later time**
- **Only the transaction log is persisted immediately to disk**

# Single CPU

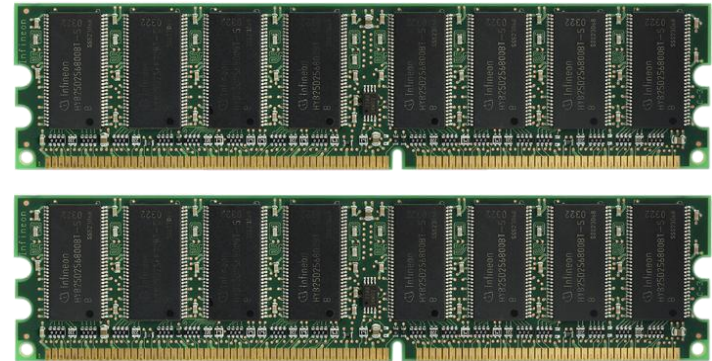

# Single CPU / Dual Core

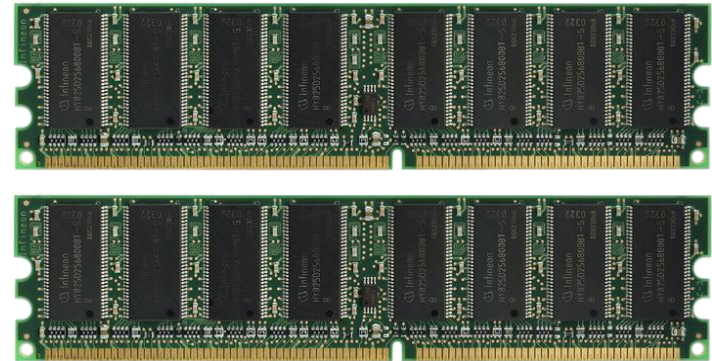
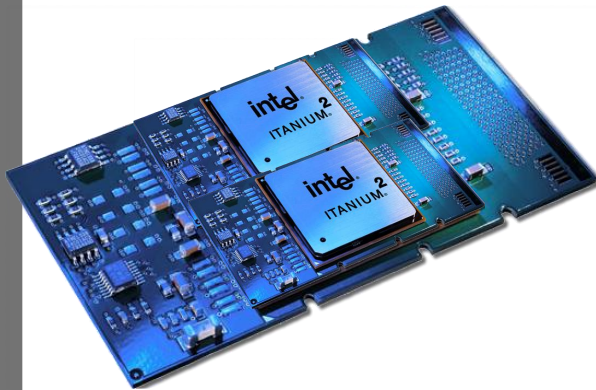

# Single CPU / Multi Core

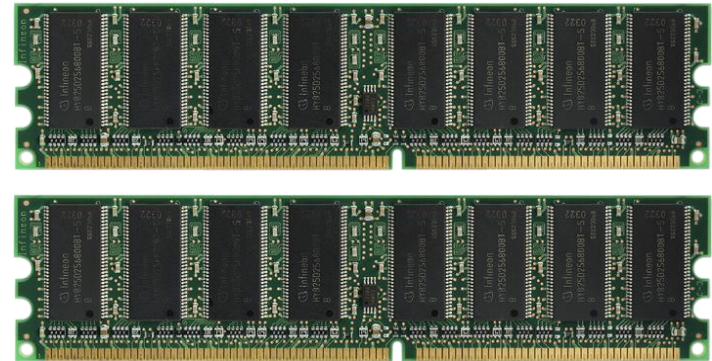

# Dual CPU

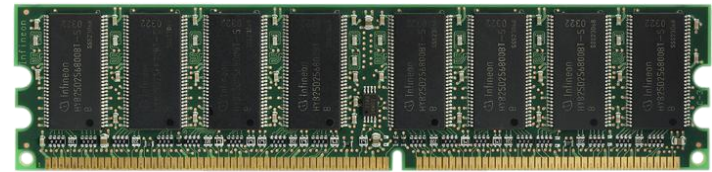
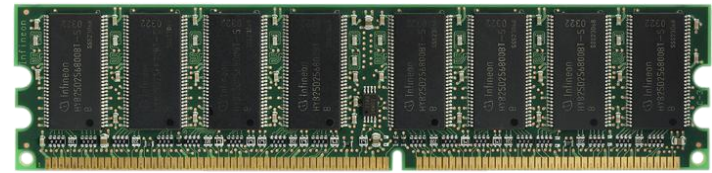

???

# Dual CPU / Solution

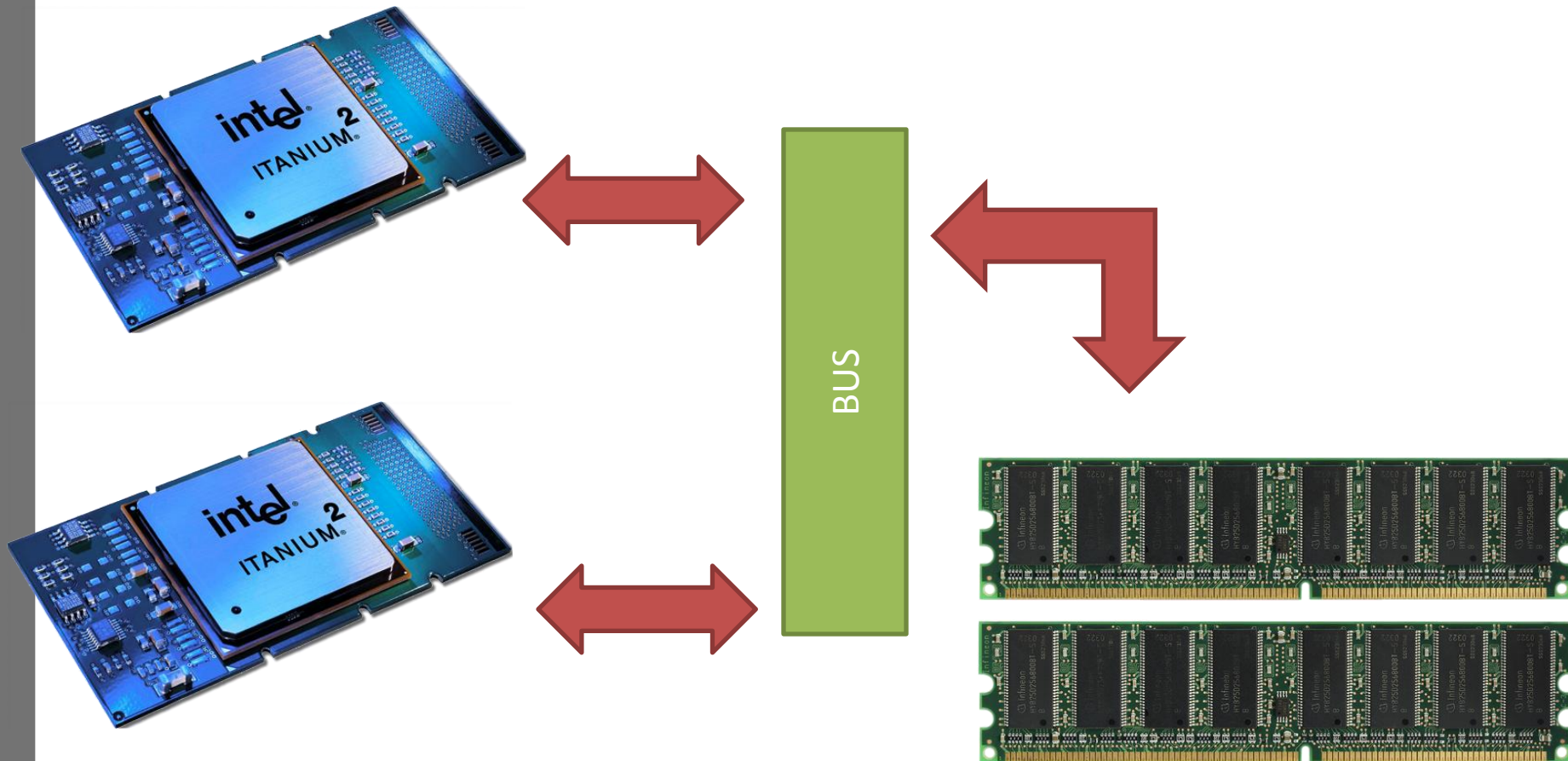

# Quad CPU Solution

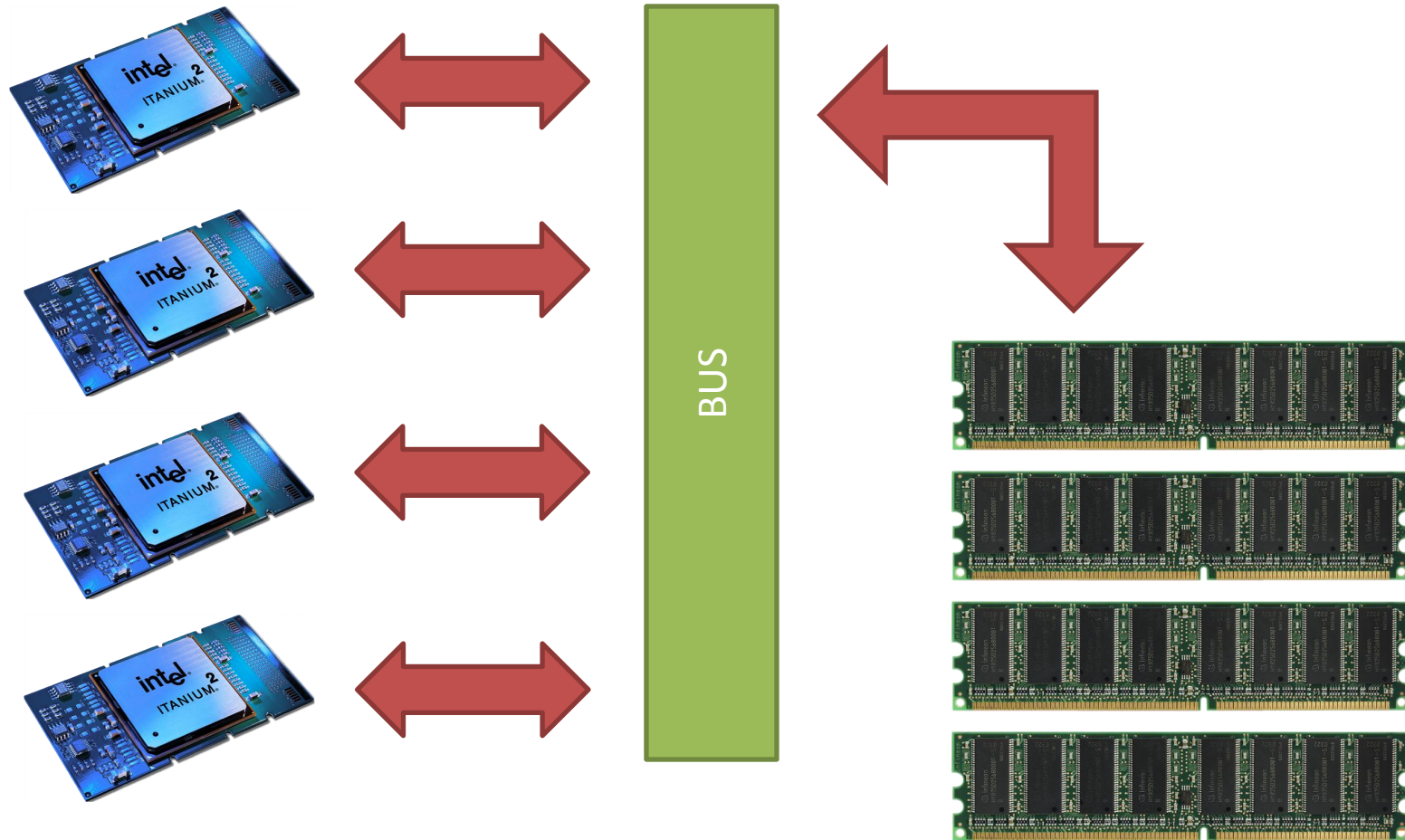

# Octal CPU Solution

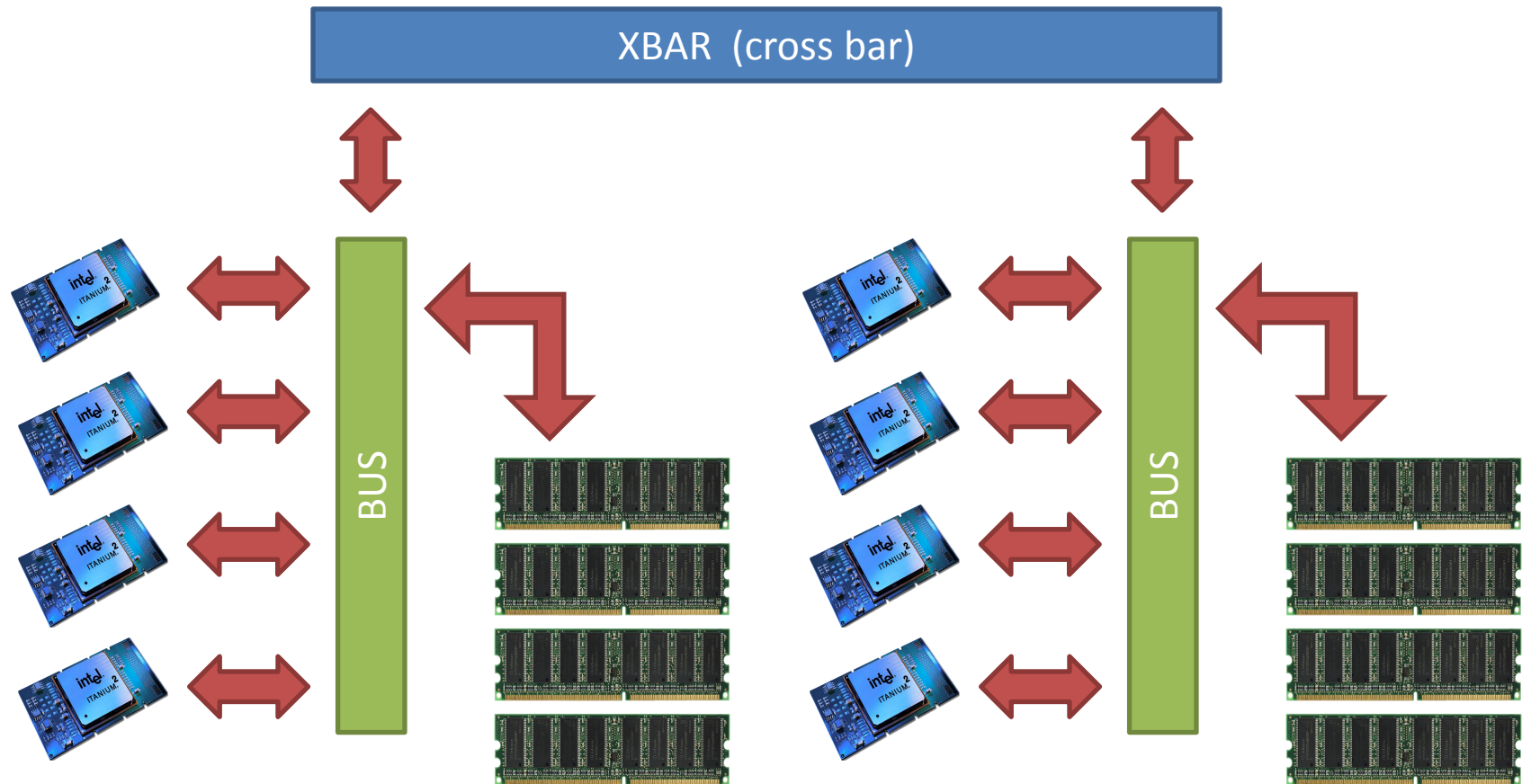

# >8 CPU Solution

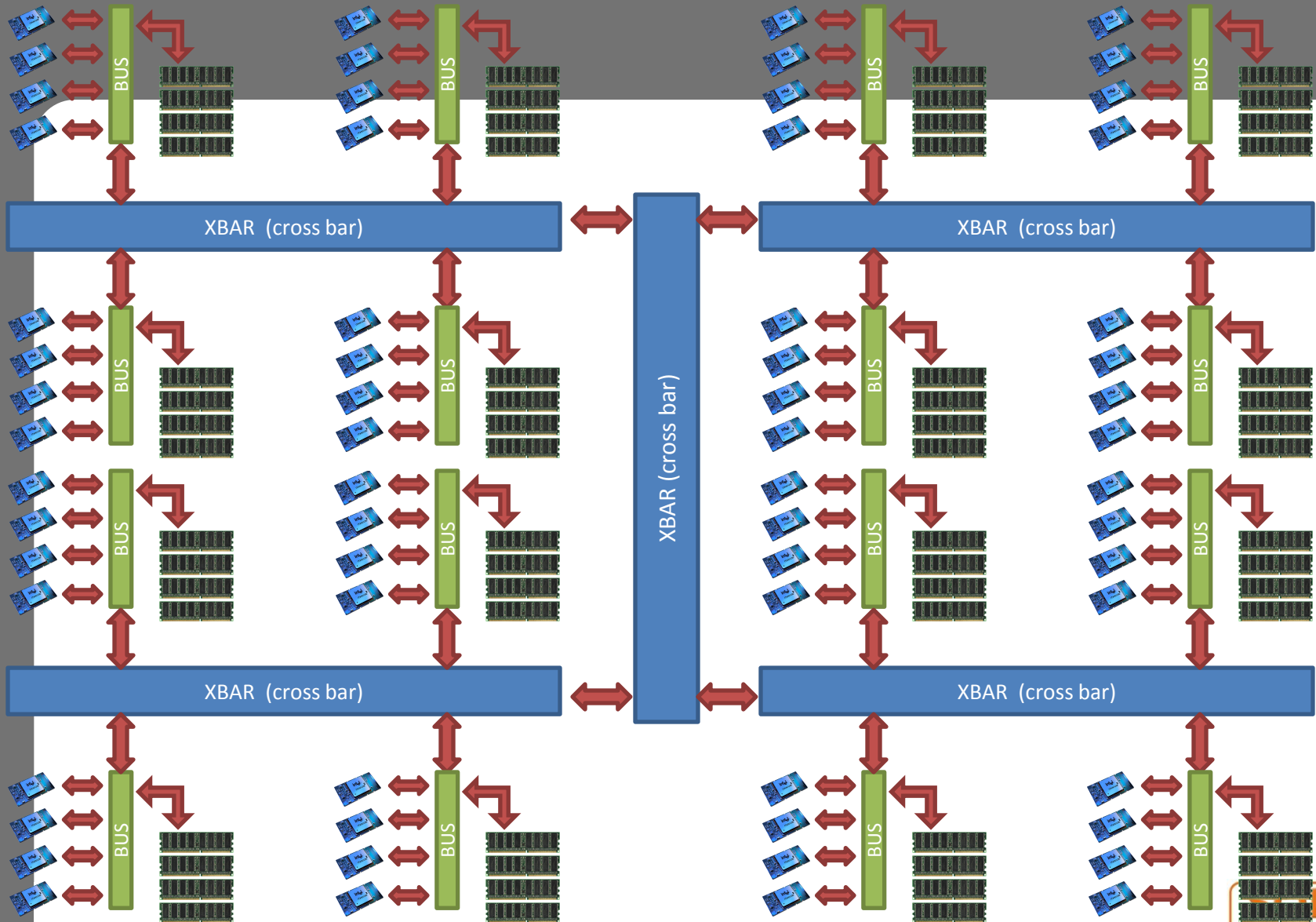

# NUMA

- **No longer a high end server feature**
- **Almost every  $\geq 2$  CPU server is now a NUMA system.**

# Dual CPU / Solution

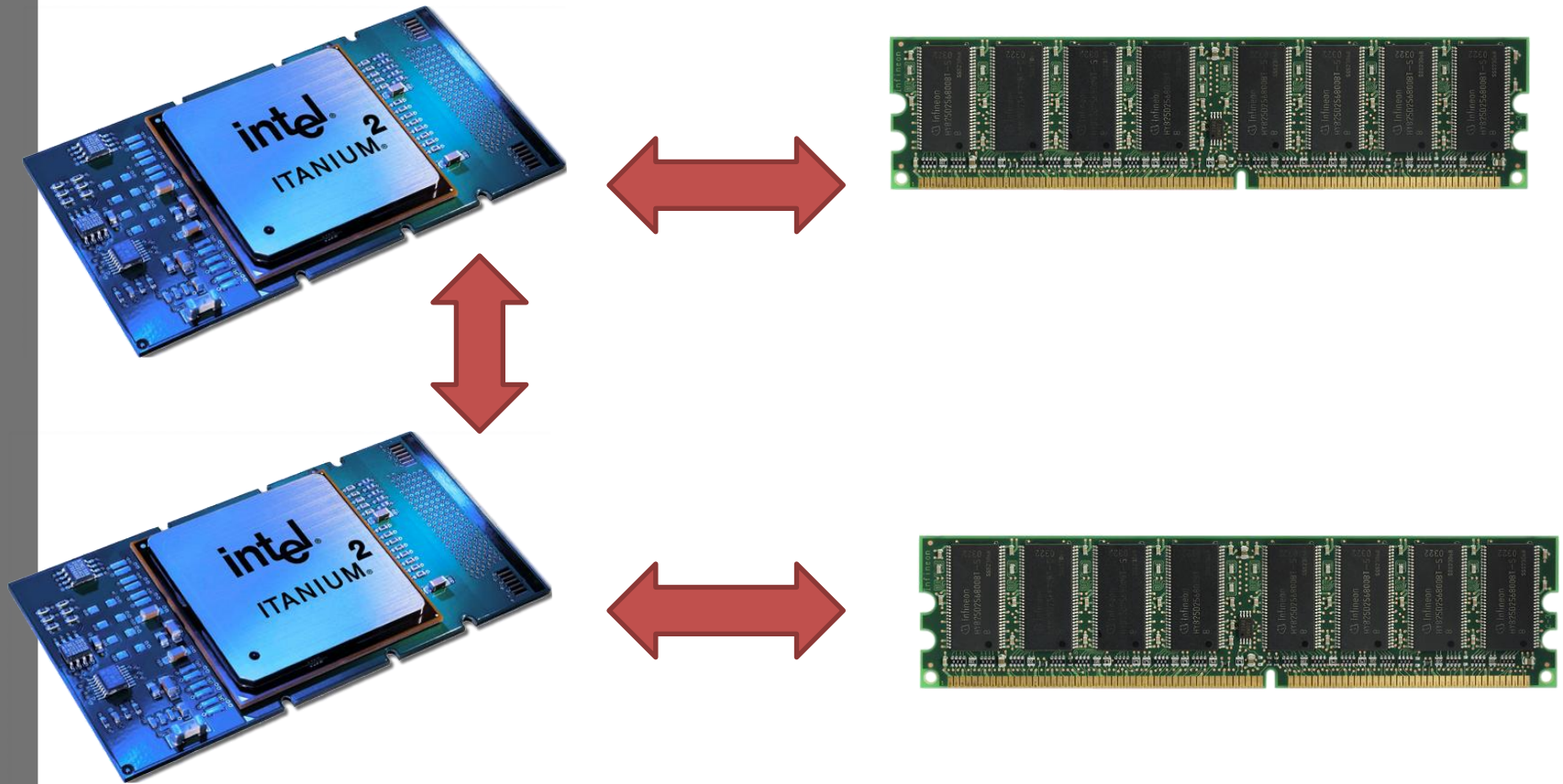

# Quad CPU Solution

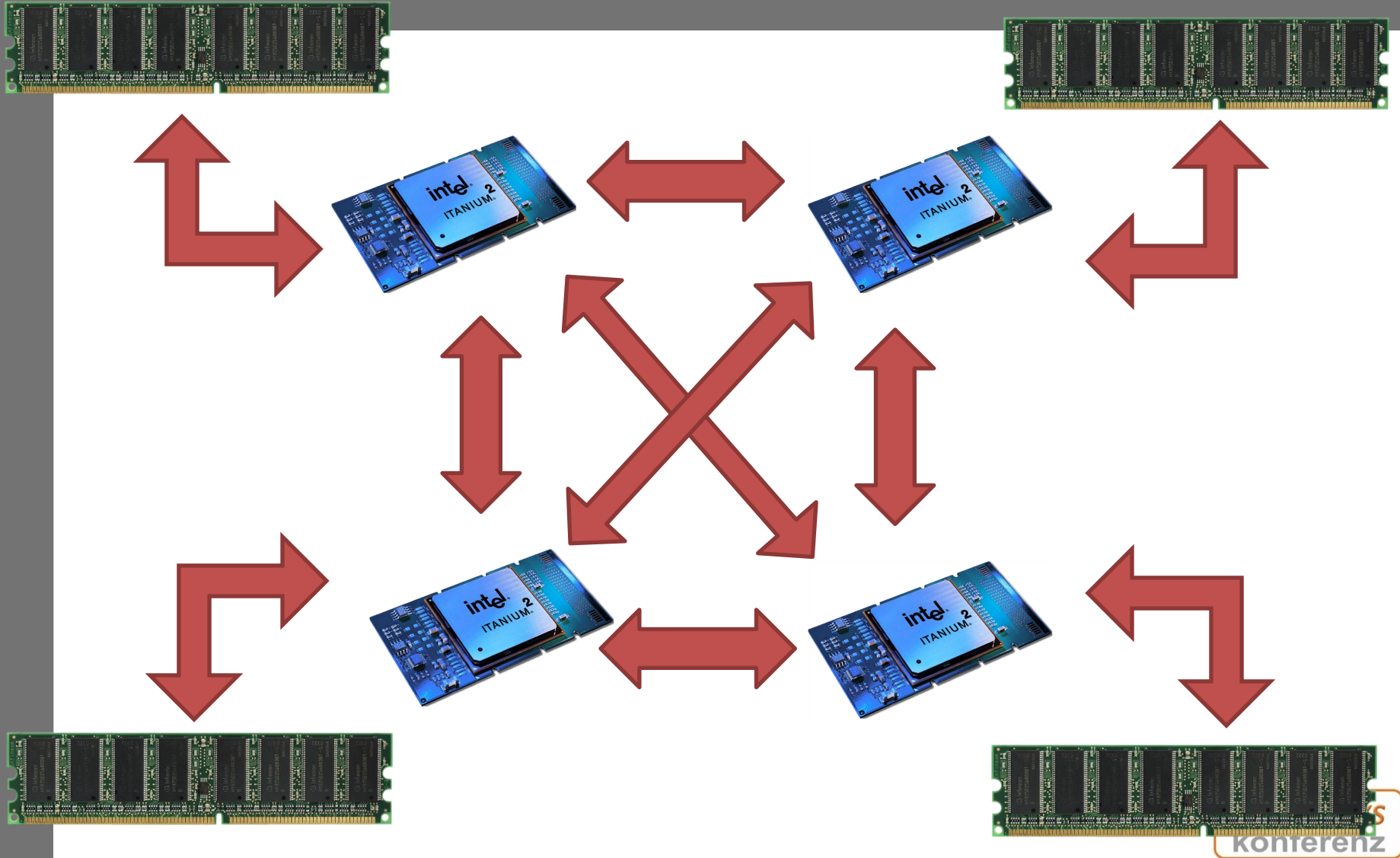

# Octal CPU Solution

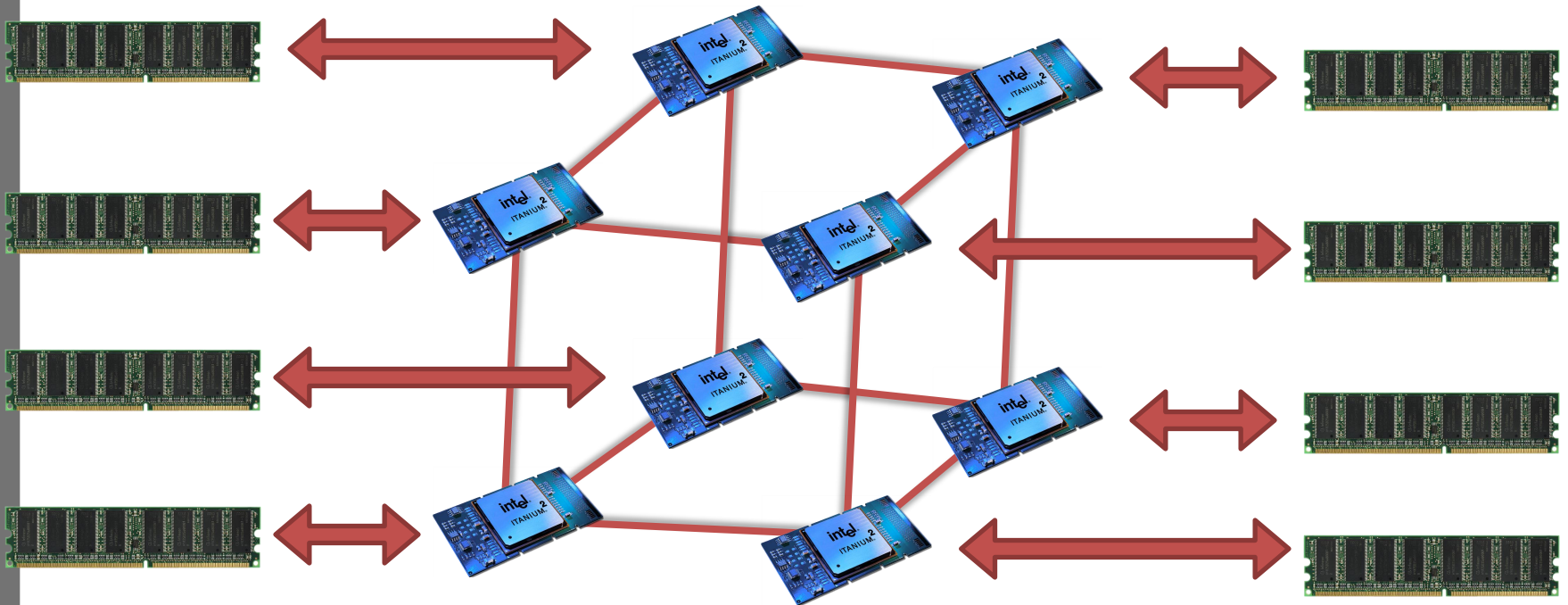

# How To Use it for SQL Server

- **How SQL Server uses Memory**
  - Allocation from the Buffer Pool
  - Allocation from Server Memory
- **How SQL Server uses Memory on a NUMA System**
  - Allocation from the local Buffer Pool
  - Allocation from local NUMA Node memory

# Not NUMA friendly

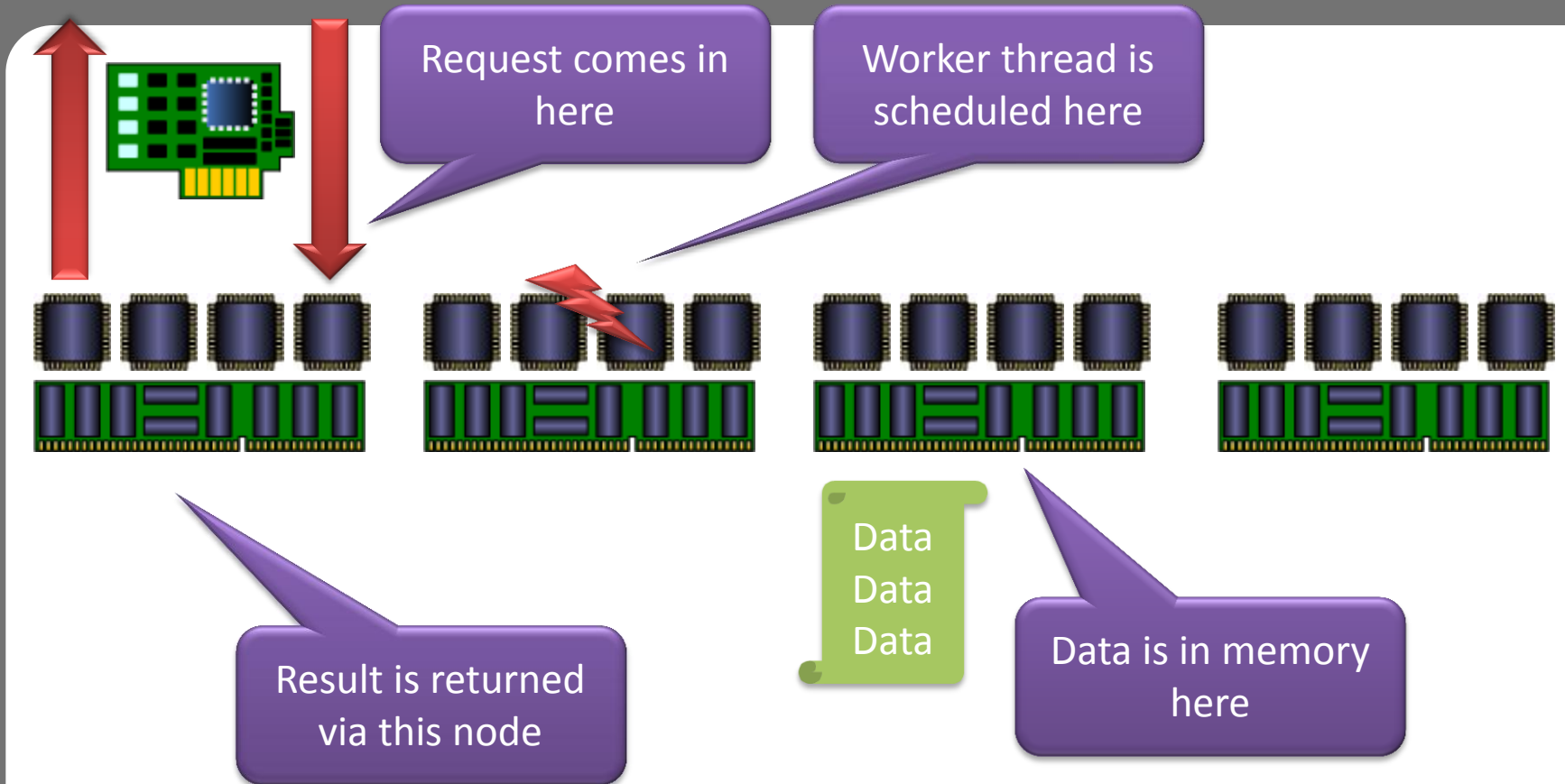

# NUMA Friendly way

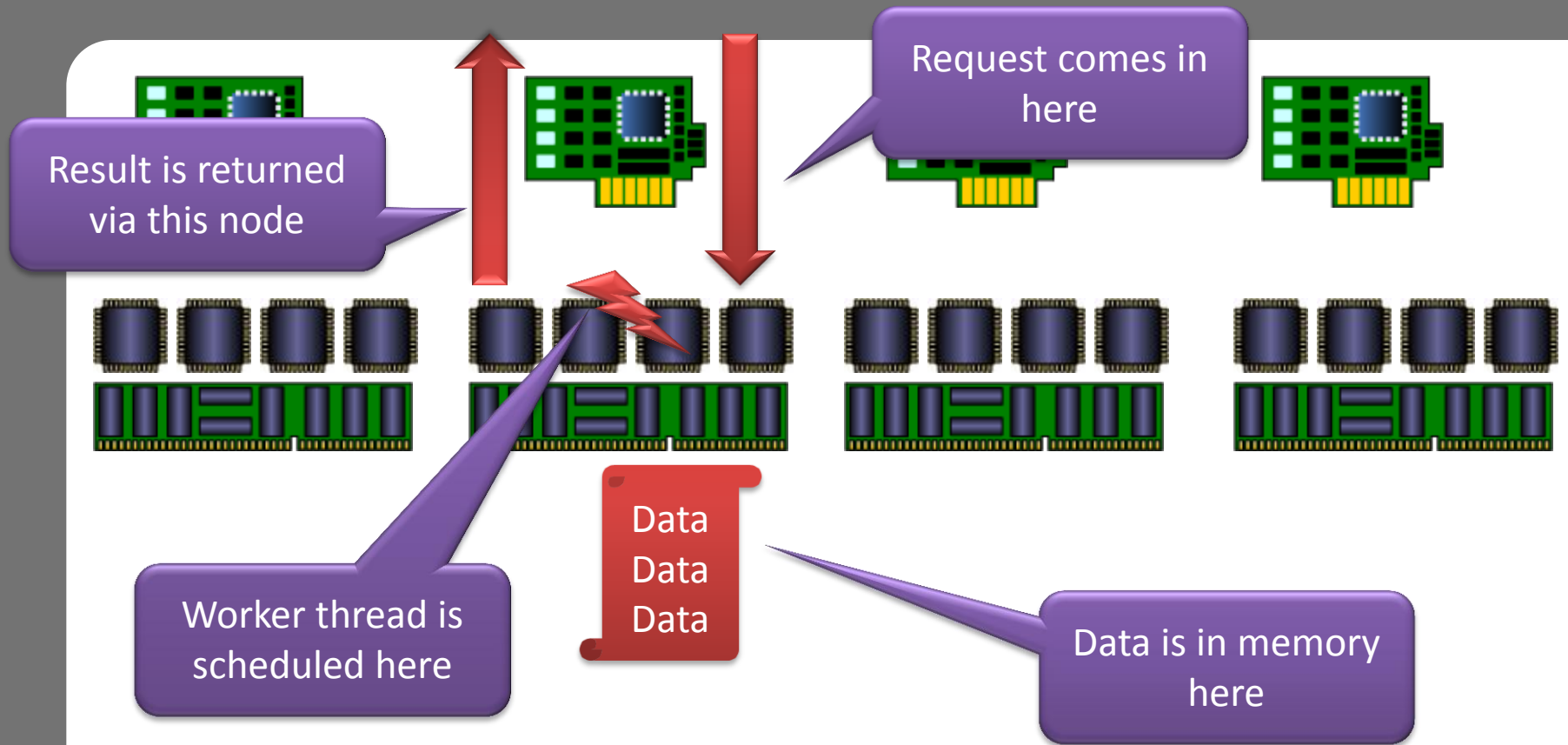

# What is easy to affinitize

- **Fully Transparent to the Application**
  - Multiple databases on the same server used by different application
  - Same database but different applications accessing different parts of the database
- **With Application Support**
  - Partition the data within one application and process each partition on a separate node

# Multiple Databases and Applications

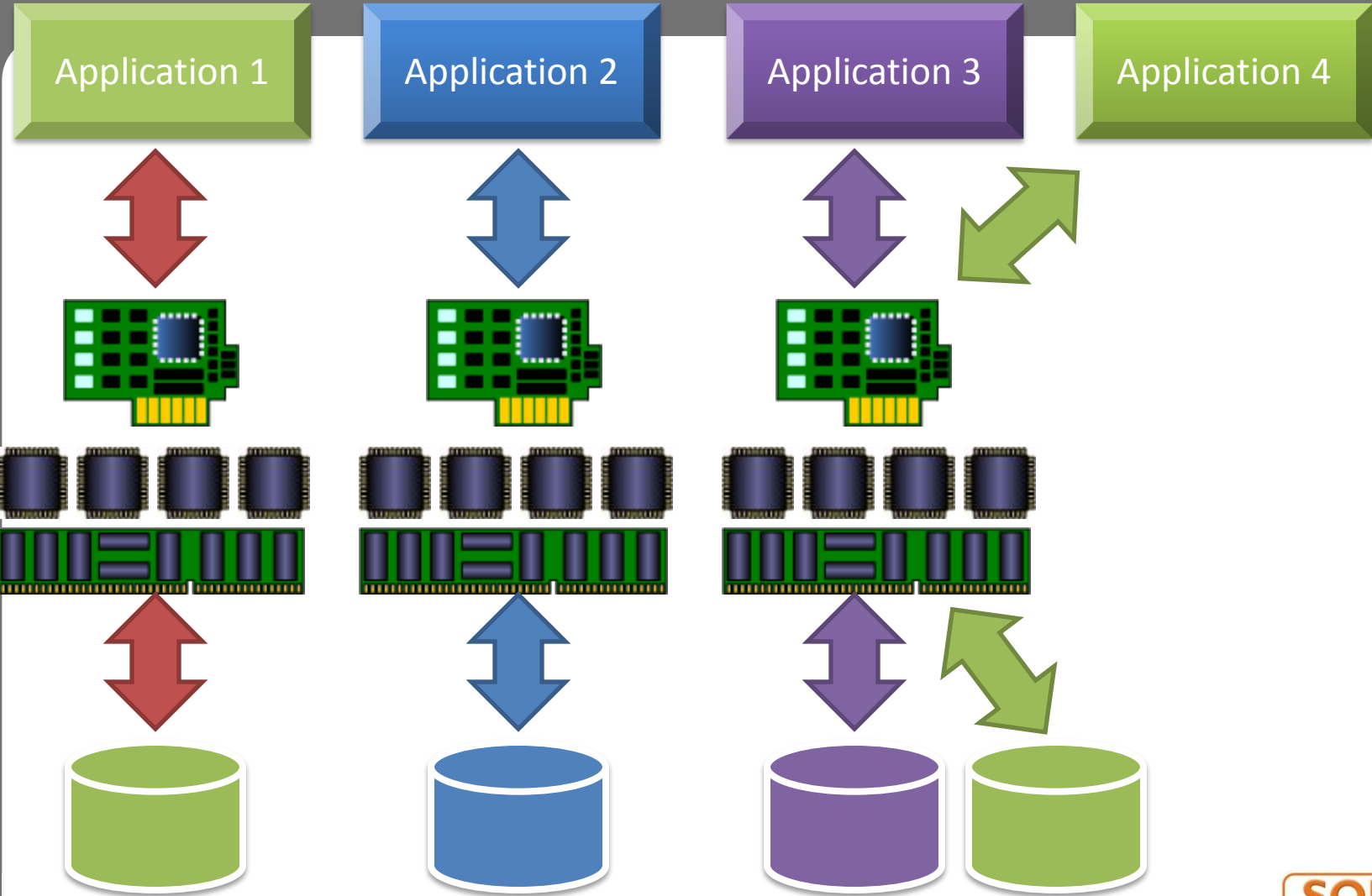

# Same Database / Multiple Applications

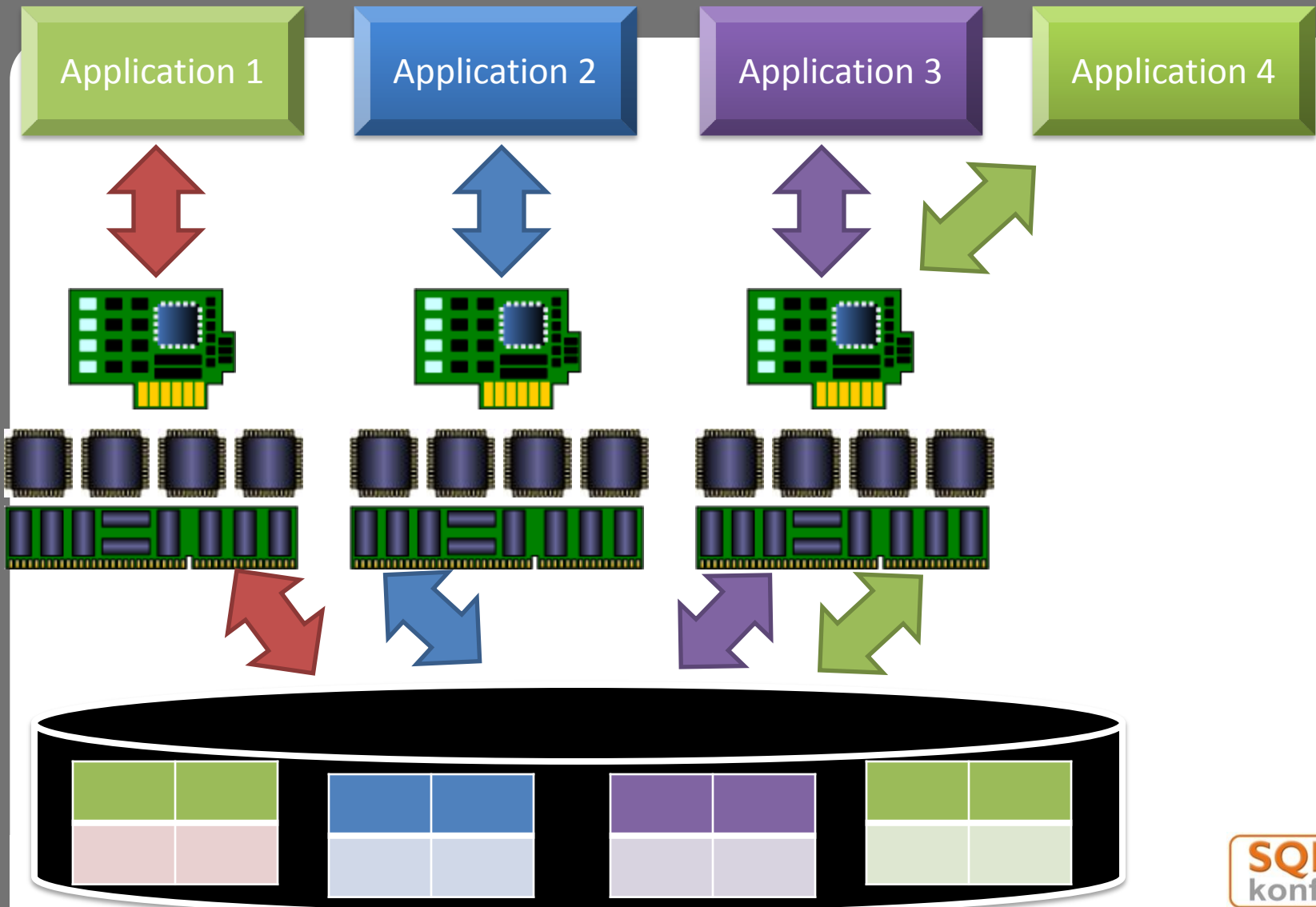

# Same Database and Application

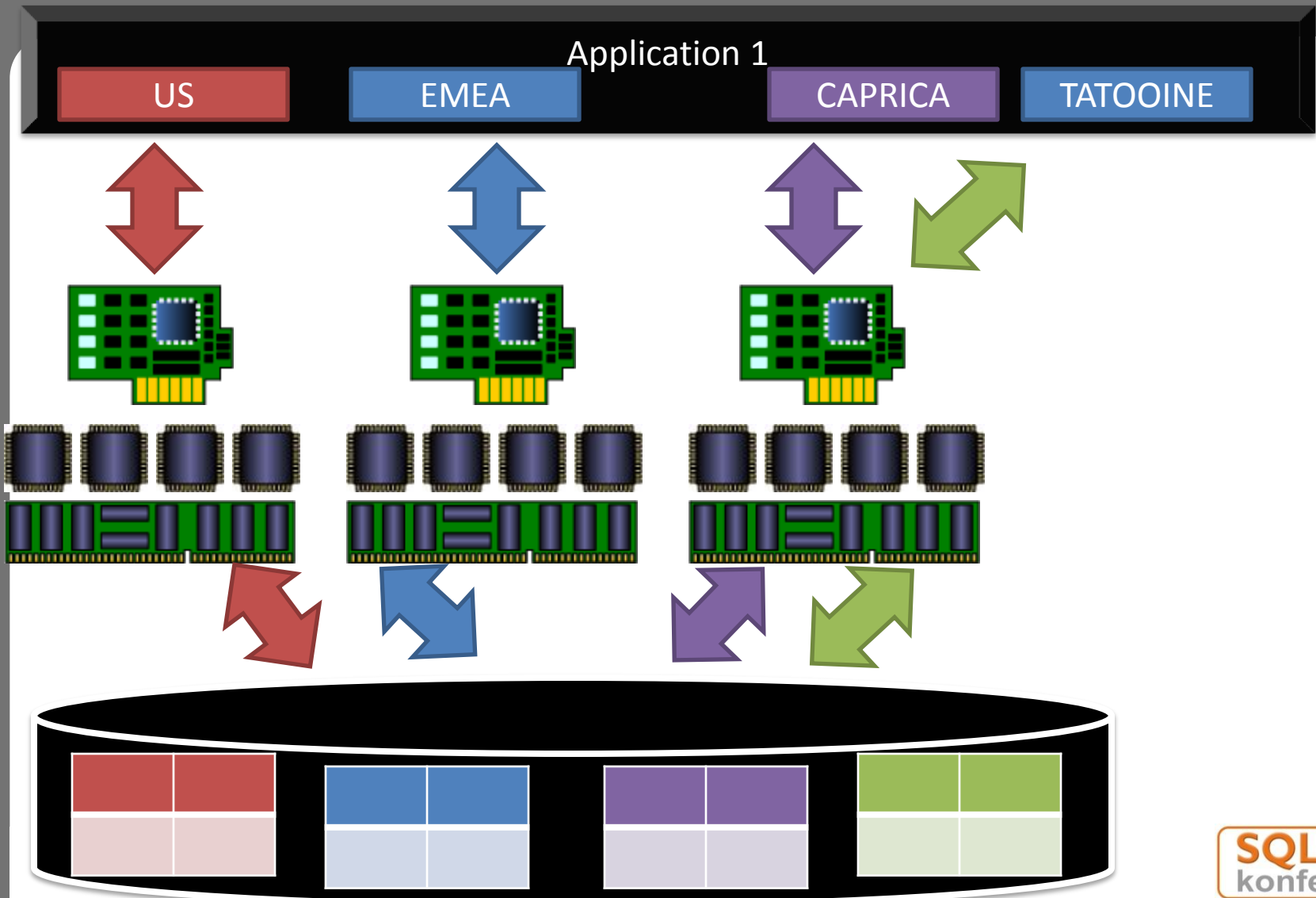

# How to Affinitize

- You can map a NUMA node to an IP Address and Port

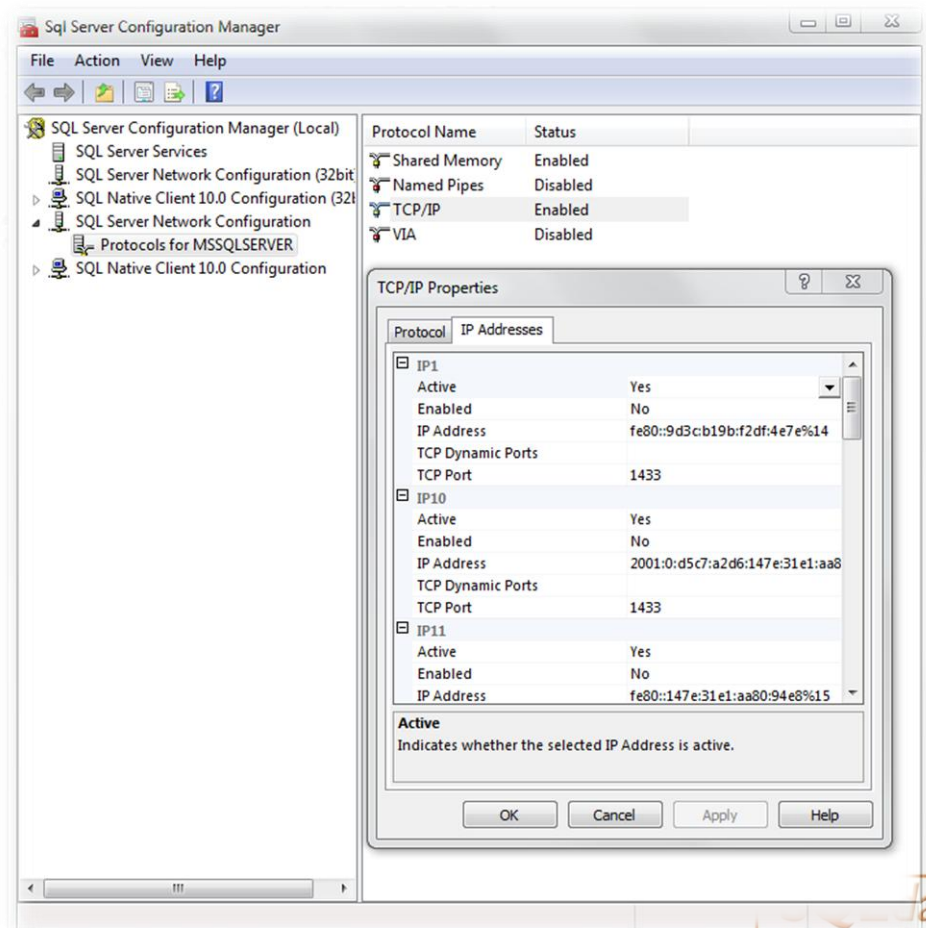

# How to Affinitize

- **<port number>[<affinity bit mask>]**
- **Single Port Examples**
  - 1500[0x1] → NUMA Node 0
  - 1600[0x2] → NUMA Node 1
  - 1700[0x4] → NUMA Node 2
  - 1800[0x7] → NUMA Node 0,1,2

# How to Affinitize

- You can also combine the settings
- 1500[0x1],1501[0x2],1502[0x3],1433[0xf]

1433 uses all Nodes, while 1500 to 1502 use one node each

# How to connect from an Application

```
string generalConnectionString =  
"Server=MyServer;Database=MyDB;...";
```

```
string node1ConnectionString =  
"Server=MyServer,1500;Database=MyDB;...  
"
```

```
string node2ConnectionString =  
"Server=MyServer,1501;Database=MyDB;...  
"
```

# Good vs Bad Server design



- **All I/O in one node**



- **Put OS Disks in the OS node**

- Node 0 on most systems, depends on CPU and Server manufacturer (on some system OS is in last node)

- **Enable NUMA**

- Setting often called Interleaved memory On / Off
- Tricky setting:

**On** = NUMA OFF or Disabled

**Off** = NUMA ON or Enabled (the good stuff)



# Good vs Bad Server design

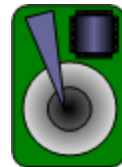
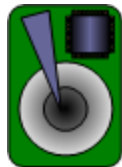
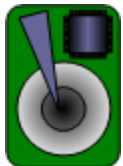
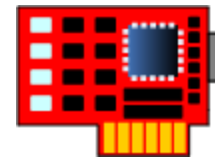
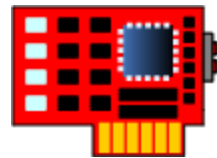
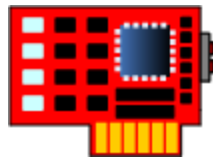
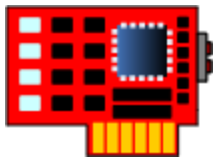
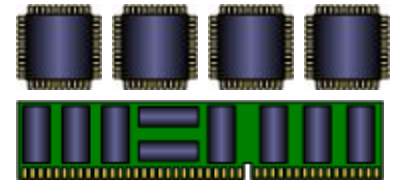
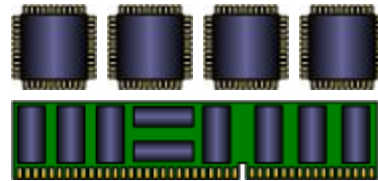
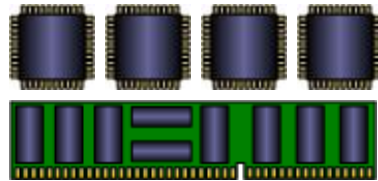
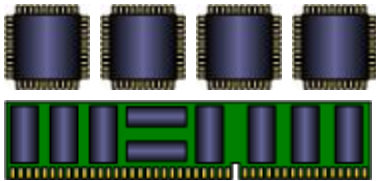
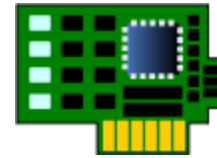
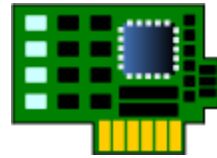
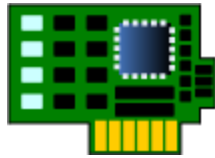
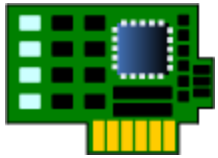

# SQL Server Error log

- On a NUMA enabled system you will find the following entries in the error log

<date> <time> Server Node configuration:

node 0: CPU mask: 0x00000000000000f0 Active CPU mask: 0x00000000000000f0  
node 1: CPU mask: 0x000000000000000f Active CPU mask: 0x000000000000000f  
node 2: CPU mask: 0x0000000000000f00 Active CPU mask: 0x0000000000000f00  
node 3: CPU mask: 0x000000000000f000 Active CPU mask: 0x000000000000f000  
node 4: CPU mask: 0x00000000000f0000 Active CPU mask: 0x00000000000f0000  
node 5: CPU mask: 0x000000000f000000 Active CPU mask: 0x000000000f000000  
node 6: CPU mask: 0x00000000f0000000 Active CPU mask: 0x00000000f0000000  
node 7: CPU mask: 0x0000000f00000000 Active CPU mask: 0x0000000f00000000

This message provides a description of the NUMA configuration for this computer.

This is an informational message only. No user action is required.

# Avoiding Context Switches

```
exec sp_configure 'show advanced options', 1  
reconfigure
```

```
exec sp_configure 'affinity mask', 0x0002  
reconfigure
```

## HEX Value is CPU mask; One bit per CPU

Bit =1 CPU is used and a Worker Thread will not switch once started

Bit = 0 CPU is not used

All Bits = 0 (default) all CPU's are used but worker threads can switch from CPU to CPU

(this costs time only good on mixed OLTP/DSS/BI systems)

# Dedicating CPU's for I/O

- `exec sp_configure 'affinity I/O mask', 0x0002`
- If a CPU is dedicated to I/O corresponding bits in the affinity mask must be 0

Affinity Mask	0	0	1
Affinity I/O Mask	0	1	0



## >32 CPUs

For the CPUs 33 to 64 there is a second pair of configuration values:

```
exec sp_configure 'affinity64 mask', 0x0000
```

```
exec sp_configure 'affinity64 I/O mask', 0x0000
```

# >64 CPU's: Windows 2008 R2 and SQL Server 2008 R2

- **Unisys ES7000 96 cores Xeon**
- **HP Superdome 128/256 cores Itanium**
- **More CPU's and cores to come in the future**

## **ALTER SERVER CONFIGURATION**

### **SET PROCESS AFFINITY**

**CPU = { AUTO | <range\_spec> } |**

**NUMANODE = <range\_spec>**

# >64 CPU's: Windows 2008 R2 and SQL Server 2008 R2

**ALTER SERVER CONFIGURATION SET PROCESS AFFINITY CPU =  
AUTO**

**ALTER SERVER CONFIGURATION SET PROCESS AFFINITY CPU = 0**

**ALTER SERVER CONFIGURATION SET PROCESS AFFINITY CPU = 2 to  
8**

**ALTER SERVER CONFIGURATION SET PROCESS AFFINITY CPU = 2 to  
8, 12 to 100, 107**

**ALTER SERVER CONFIGURATION SET PROCESS AFFINITY  
NUMANODE = 0, 2 TO 4, 7, 8**

# Side effect: Save licensing costs

- You have a lot of CPU's its very likely that one or more CPU for I/O might make sense
- Example 32 CPU's and we dedicate one per NUMA node for I/O

```
exec sp_configure 'affinity mask', 0x77777777
```

```
exec sp_configure 'affinity I/O mask', 0x88888888
```

→ Only 24 CPU licenses are required for SQL Server

# Wrap Up

- **NUMA has arrived or will arrive at your datacenter soon**
- **NUMA makes local memory access faster not remote memory access slower, without NUMA all memory access would be like remote!**
- **Make NUMA your friend by actively supporting it**

FRAGEN



# Hat Ihnen mein Vortrag gefallen?

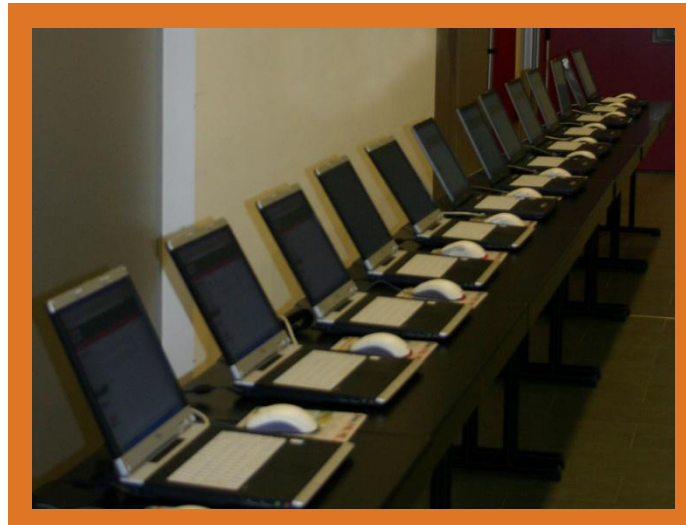

**Ich freue mich auf Ihr Feedback!**

# Wir sehen uns wieder:



- **building & connecting Know-how**
  - 16.-17. Februar 2011 in München
  - .NET, Visual Studio, SharePoint & more!

[www.VSone.de](http://www.VSone.de)



- **Trainings und Events der ppedv**
  - Mehr als 90 verschiedene Trainings
  - auf Microsoft-Technologien spezialisiert
  - 11 Standorte in D & AT
  - Maßgeschneiderte Trainings direkt bei Ihnen vor Ort!

[www.ppedv.de](http://www.ppedv.de)



**SQLdays**  
konferenz

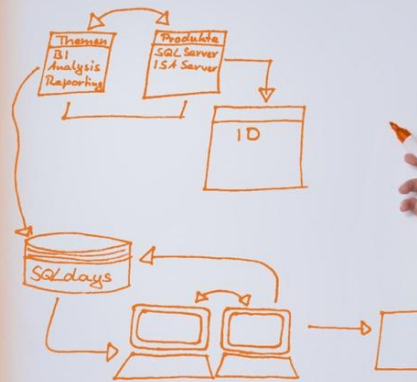

**VIELEN DANK!**

=tg= Thomas Grohser

Veranstalter:

